

FIGARO

an ISO9001/14001 company

Technical Information for Carbon Monoxide Sensors

Figaro's TGS5042 is a battery operable electrochemical sensor which offer several advantages over traditional electrochemical sensors. Its electrolyte is environmentally friendly, it poses no risk of electrolyte leakage, can detect concentrations as high as 1% CO, operates in a range from -40° and +70°C, and it has lower sensitivity to interferant gases. With a long life, good long term stability, and high accuracy, this sensor is the ideal choice for CO detectors with digital display. OEM customers will find individual sensors data printed on each sensor in bar code from, enabling users to skip the costly gas calibration process and allowing for individual sensor tracking. TGS5042 utilizes a standard AA battery-sized package.



<i>Specifications</i>	<i>Page</i>
Features.....	2
Applications.....	2
Structure.....	2
Basic Measuring Circuit.....	2
Operating Conditions & Specifications.....	3
Mechanical Strength.....	3
Dimensions.....	3
<i>Operation Principle</i>	4
<i>Basic Sensitivity Characteristics</i>	
Sensitivity to Various Gases.....	5
Temperature and Humidity Dependency.....	5
Gas Response Pattern.....	6
Repeatability.....	6
Influence of Storage.....	6
Normal Operation Test.....	7
Sensitivity Test.....	7
<i>Reliability</i>	
Interference Gas Test.....	8
Long-Term Stability.....	9
Corrosion Test.....	9
Variable Ambient Temperature Test.....	9
Humidity Test.....	10
Stability Tests.....	11
Sequential Test.....	11
Dust Test.....	12
Water Loss Test.....	12
<i>Marking</i>	12
<i>Notes</i>	13
<i>Appendix</i>	14

IMPORTANT NOTE: OPERATING CONDITIONS IN WHICH FIGARO SENSORS ARE USED WILL VARY WITH EACH CUSTOMER'S SPECIFIC APPLICATIONS. FIGARO STRONGLY RECOMMENDS CONSULTING OUR TECHNICAL STAFF BEFORE DEPLOYING FIGARO SENSORS IN YOUR APPLICATION AND, IN PARTICULAR, WHEN CUSTOMER'S TARGET GASES ARE NOT LISTED HEREIN. FIGARO CANNOT ASSUME ANY RESPONSIBILITY FOR ANY USE OF ITS SENSORS IN A PRODUCT OR APPLICATION FOR WHICH SENSOR HAS NOT BEEN SPECIFICALLY TESTED BY FIGARO.



TGS5042 is a UL recognized component in accordance with the requirements of UL2034. Please note that component recognition testing has confirmed long term stability in 15ppm of carbon monoxide; other characteristics shown in this brochure have not been confirmed by UL as part of component recognition.

1. Specifications

1-1 Features

- * Battery operable
- * High repeatability / selectivity to carbon monoxide
- * Linear relationship between CO gas concentration and sensor output
- * Simple calibration
- * Long life
- * UL recognized component
- * Meets UL2034, EN50291, and RoHS requirements

1-2 Applications

- * Residential and commercial CO detectors
- * CO monitors for industrial applications
- * Ventilation control for indoor parking garages
- * Recreational vehicle CO detectors
- * Marine CO detectors
- * Fire detection

1-3 Structure

Figure 1 shows the structure of TGS5042. The gas sensing layer is sandwiched between a stainless steel washer (counter electrode) and a stainless steel cap (working electrode), together with gas diffusion control stainless film and backing layers. This assembly is placed in the compartment of the stainless steel can. Water is stored in the bottom compartment and a charcoal filter is installed inside the stainless steel cap.

1-4 Basic measuring circuit

Figure 2 shows the basic measuring circuit of TGS5042. The sensor generates a minute electric current which is converted into sensor output voltage (V_{out}) by an op-amp/resistor (R_1) combination.

Figaro recommends the following electrical parts:

- R1 : 1M Ω
- C1 : 22 μ F
- IC : AD708

An additional resistor or FEF is required to prevent polarization of the sensor when circuit voltage is off.

NOTE: When voltage is applied to the sensor output terminal, the sensor may be damaged. Voltage applied to the sensor should be strictly limited to less than ± 10 mV.

1-5 Operating conditions & specifications (Table 1)

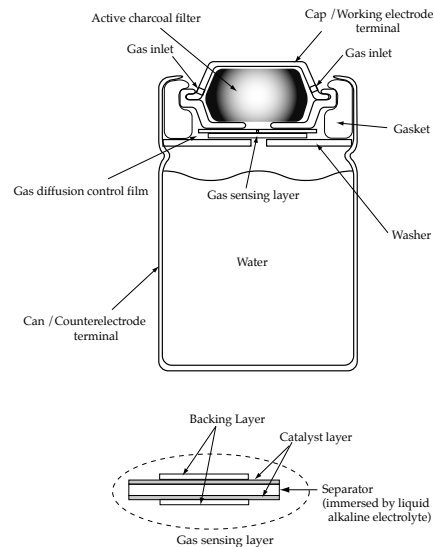

Figure 1 - Sensor structure

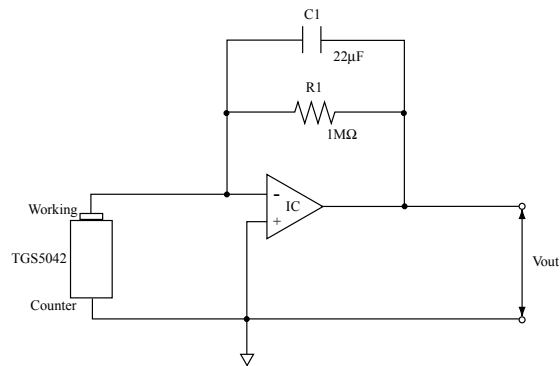

Figure 2 - Basic measuring circuit (Including equivalent circuit)

Item	Specification
Model number	TGS 5042
Target gases	Carbon monoxide
Typical detection range	0 ~ 10,000 ppm
Output current in CO	1.2~2.4nA/ppm
Baseline offset (*)	$\leq \pm 10$ ppm equivalent
Operating temperature	-10°C ~ +60°C (continuous) -40°C ~ +70°C (intermittent)
Operating humidity	5 ~ 99%RH (no condensation)
Response time (T90)	within 60 seconds
Storage conditions	-10°C ~ +60°C (continuous) -40°C ~ +70°C (intermittent)
Weight	approx. 12g
Standard test conditions	20 \pm 2°C, 40 \pm 10%RH

NOTE 1: Sensor output in air under operating conditions

Table 1 - Operating conditions and specifications

1-6 Mechanical strength

The sensor shall have no abnormal findings in its structure and shall satisfy the above electrical specifications after the following performance tests:

Withstand force -

withstand force of 10kg (cap from metal can) along a vertical axis

Vibration - frequency--10~500Hz (equiv. to 10G), duration - 6 hours, x-y-z direction

Shock - acceleration-100G, repeat 5 times

All sensor characteristics shown in this brochure represent typical characteristics. Actual characteristics vary from sensor to sensor and from production lot to production lot. The only characteristics warranted are those shown in the Specification.

1-7 Dimensions (see Fig. 3)

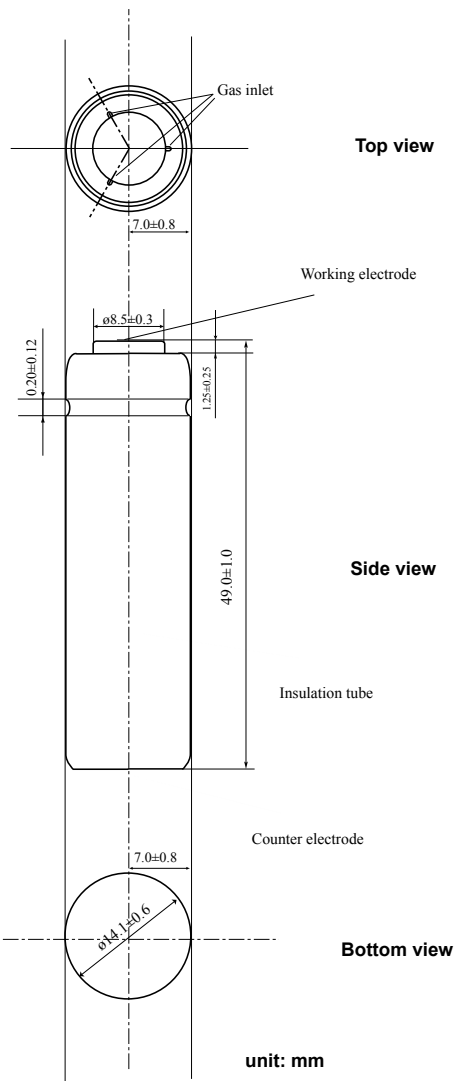

NOTE: The sensor can be supplied with lead pins. Please refer to the *Appendix* for details

Figure 3 - Dimensions

2. Operation Principle

The electrolyte of TGS5042 is a very low concentration of mixed/prepared alkaline electrolyte consisting of KOH, KHCO₃, and K₂CO₃. The mixed alkaline electrolyte acts as a buffer solution with a pH value maintained between 7~10. When CO passes through the backing layer and reaches to the working electrode, electrons are generated resulting from the reaction between CO and anions in the electrolyte such as OH⁻, HCO₃⁻, and CO₃²⁻ (see equations 1a~1c). By creating a short circuit between the working and counter electrodes with external wiring, electrons move to the counter electrode through the external wiring. At that point, the consumed anions in the electrolyte at the working electrode are replenished and move to the electrolyte by the reaction of CO₂, water, and electrons as shown in equations 2a~2c. The total reaction is expressed as shown in equation 3.

A linear relationship exists between the sensor's electric current and CO concentration (see equation 4). By calibrating the sensor with a known concentration of CO gas, the output current of the sensor can then be used to quantitatively determine CO concentration.

Since, unlike conventional dry batteries, there is no consumption of active materials or of the electrodes, TGS5042 possesses excellent long-term stability for its output signal and enables maintenance-free operation. Furthermore, the sensor's self-generating output current makes it ideal for usage in battery-operated CO detectors.

Working electrode (Anodic reaction)

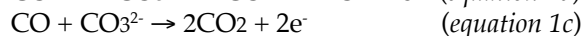
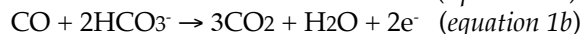
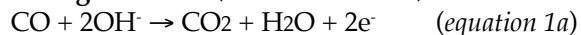

Counter electrode (Cathodic reaction)

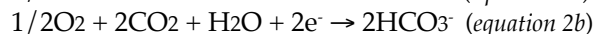

Total reaction

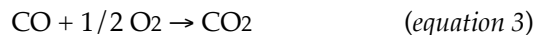

Theoretical output current value

$$I = F \times (A/\sigma) \times D \times C \times n \quad (\text{equation 4})$$

where:

F : Faraday constant

A : Surface area of diffusion film

D : Gas diffusion co-efficient

C : Gas concentration

σ : Thickness of diffusion film

n : Number of reaction electrons

Figure 4 - Operation principle

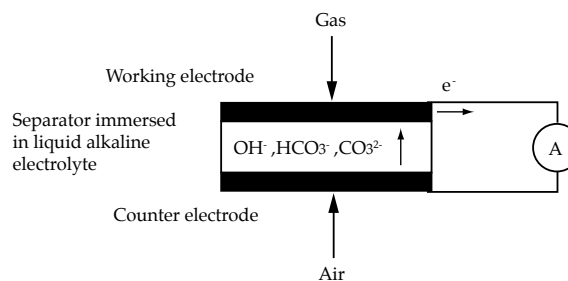

Figure 5 - Schematic diagram of TGS5042 operating principle

3. Basic Sensitivity Characteristics

3-1 Sensitivity to various gases

Figure 6 shows the sensor’s sensitivity to various gases. The Y-axis shows output current ($I_{out}/\mu A$) in each gas. The output current is linear to CO concentration, with a deviation of less than $\pm 5\%$ in the range of 0~500 ppm. Cross sensitivity data for other gases than those in Figure 6 are tabulated in Table Y.

Gas		Concentration	CO equivalent
Hydrogen		1000ppm	<350ppm
Methane	Heptane	1000ppm	<30ppm
Butane	IPA		
BtOH	Freon R22		
HMDS (Si vapor)	Acetylene		
Toluene	Ethylene		
NO2	Hexane		
Benzene chloride	CO2	200ppm	<30ppm
Formaldehyde	NH3		
Acetoaldehyde	SO2		
CH3COOH	Ethyl acetate		

Table Y - Cross sensitivity (using charcoal filter)

Note: The figures in this table are typical values and should not be used as a basis for cross calibration. Cross sensitivity for various gases may not be linear and should not be scaled. All data based on a 4 minute exposure. For some gases, filter saturation and gas breakthrough may occur if gas is applied for a longer time period.

3-2 Temperature and humidity dependency

Figure 7a shows the temperature dependency of TGS5042 under a constant humidity of 50%RH. The Y-axis shows the ratio of output current in 400ppm of CO at various temperatures (I) to the output current in 400ppm of CO at 20°C/50%RH (I_0). Temperature dependency is based on the difference in the catalytic reaction rate on the electrodes, and it can be simply compensated by utilizing a thermistor. The data displays that even at -40°C (where water in the water reservoir is frozen), the sensor has sufficient CO sensitivity. This linear relationship between I/I_0 and CO concentration is constant regardless of CO concentration range, according to the sensor's operating principle.

Figure 7b shows the humidity dependency of TGS5042 under constant temperatures of 20°C and 40°C. The Y-axis shows the ratio of output current in 400ppm of CO at various relative humidities (I) to the output current in 400ppm of CO at 20°C/50%RH (I_0). This data demonstrates that humidity dependency is negligible as temperature varies.

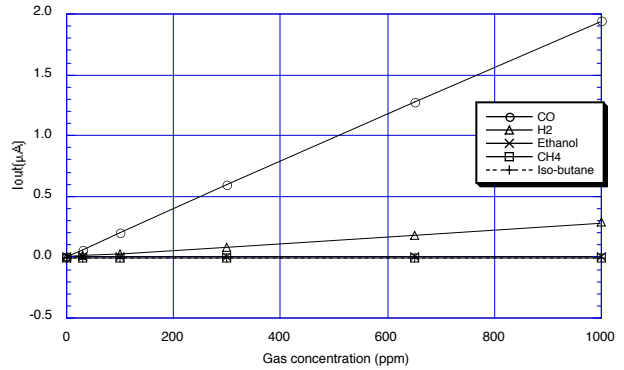

Figure 6 - Sensitivity to various gases

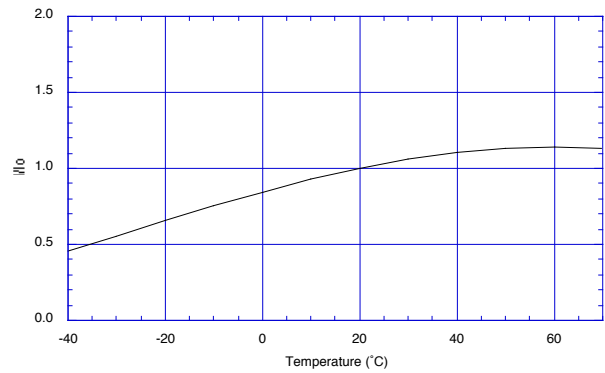

Figure 7a - Temperature dependency at 400ppm CO/50%RH (I_0 =sensor output current at 20°C)

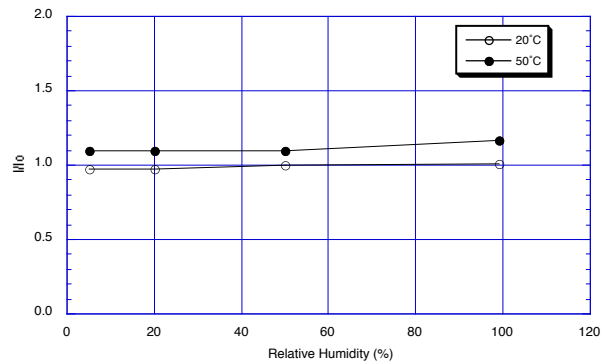

Figure 7b - Humidity dependency at 400ppm CO (I_0 =sensor output current at 50%RH)

3-3 Gas response pattern

Figure 8 shows the gas response pattern of the output signal when the sensor is placed into 30, 70, 150 and 400ppm of CO and then returned to normal air. The response time to 90% of the saturated signal level is within 60 seconds, and the recovery of the signal back to 90% of the base level is within 120 seconds. This data demonstrates that TGS5042 possesses sufficient response speed for meeting UL requirements for CO detectors.

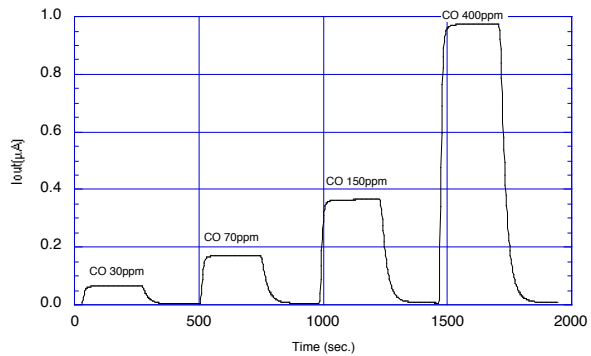

Figure 8 - Response pattern

3-4 Repeatability

Figure 9 shows the pattern of the output signal when the sensor is repeatedly exposed to 400ppm of CO at a constant interval of 240 seconds. The data demonstrates extremely high reproducibility of the output signal, the deviation being less than ±5%.

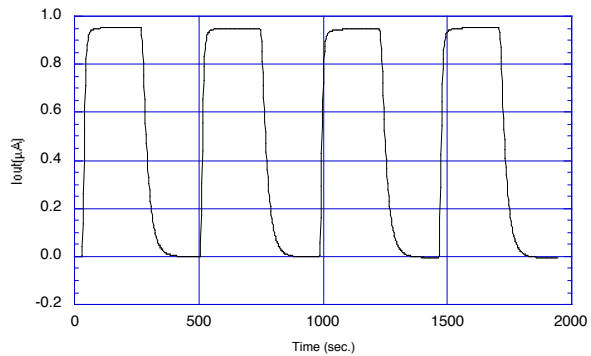

Figure 9 - Repeatability (in 400ppm of CO)

3-5 Influence of storage

Figure 10 shows the initial action of the sensor's output current signal in fresh air. For the purpose of this test, sensors were stored for more than six months under two separate conditions between the working and counter electrodes: in short-circuited condition, and in open-circuited condition. The chart illustrates the behavior of sensor output current for each group just after installation into the operating circuit. The output current signal of sensors stored in a short-circuited condition reaches its saturated level quickly, while those stored with an open-circuit exhibit much slower behavior. For this reason, TGS5042 is shipped in a short-circuited form which should be maintained just prior to assembling the sensor into a device.

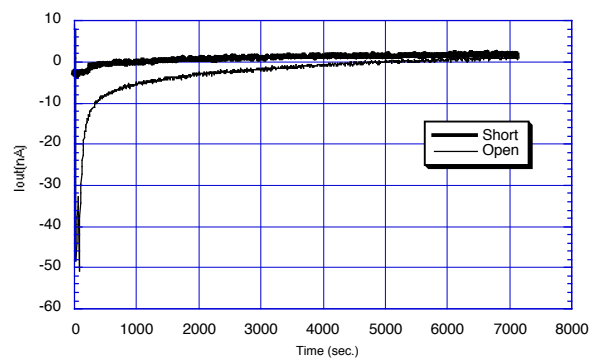

Figure 10 - Influence of storage (in fresh air)

3-6 Normal operation test

Figure 11a shows the result of the “Normal Operation Test” required by UL2034, Sec. 35.3 where the sensor is exposed to 600ppm of CO for 12 hours at 20°C/40%RH. Stable output current signal can be seen throughout the exposure.

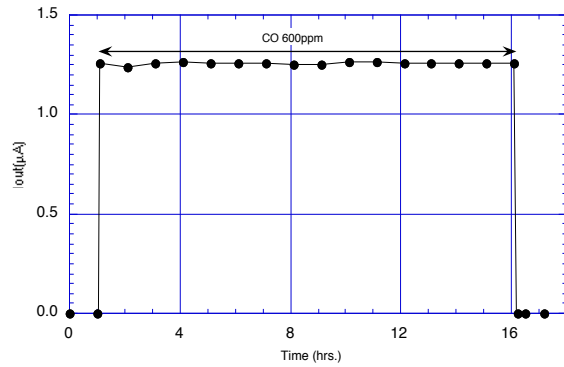

Figure 11a - Normal operation test (CO 600±30ppm for 12 hours at 20°C/40%RH)

In addition, Figure 11b shows the CO sensitivity characteristics of the sensor before, during, and after the Normal Operation Test, demonstrating that TGS5042 is hardly influenced by exposure to high concentrations of CO.

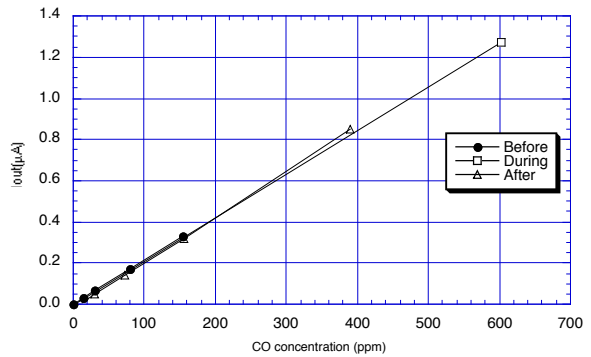

Figure 11b - Normal operation test (20°C/40%RH)

3-7 Sensitivity test

Figure 12a shows the results of the “Sensitivity Test” as required by UL2034, Sec. 38. Under this test, the sensor was exposed to 30, 70, 150 and 400ppm of CO at 20°C/40%RH. The period of exposure was varied by concentration, corresponding with the maximum time in which a CO detector should generate an alarm for the subject concentration. Throughout the test exposures, TGS5042 displayed a reasonable and stable output current signal.

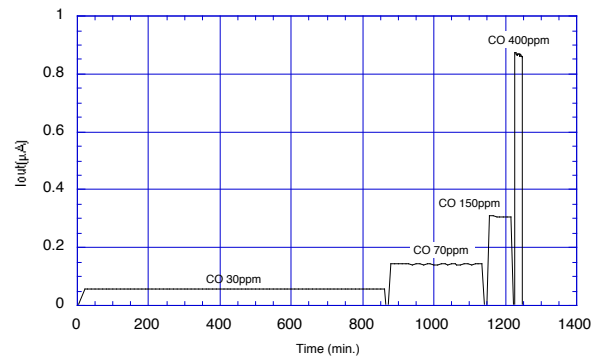

Figure 12a - Sensitivity test (20°C/40%RH)

In addition, Figure 12b indicates the CO sensitivity characteristics of the sensor before, during, and after the Sensitivity Test, demonstrating the excellent reproducibility of TGS5042's CO sensitivity characteristics.

4. Reliability

Tests conducted in this section demonstrate that TGS5042 can meet the requirements of various testing standards without incurring adverse long term effects from such tests.

4-1 Interference gas test

Figure 13a shows the results of testing the TGS5042 sensor for durability against various interference gases as specified by UL2034, Sec. 39. The test was conducted by exposing the sensor to each gas shown in Figure 13a (starting with CO 30ppm) for two hours, then removing the sensor to fresh air for just one hour, and followed by inserting the sensor into the next gas. This procedure was repeated for the full range of gases shown in Figure 13a.

Because the sensor is exposed to each of the test gases consecutively, to some small extent the effect of the previous test gas may affect subsequent tests for a short period. However, despite the short-term effects of such gases remaining after exposure, the sensor still shows significantly less sensitivity to each test gas when compared to 30ppm of CO, and CO sensitivity remains unaffected.

In addition, Figure 13b shows the CO sensitivity characteristics of the sensor before and after this test, further demonstrating the excellent reproducibility of the CO sensitivity characteristics of TGS5042, demonstrating its durability against the interference gases listed in the requirements of UL2034, Sec. 39.

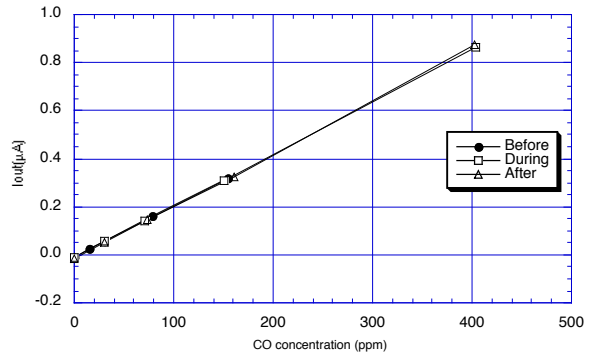

Fig. 12b - Sensitivity test (20°C/40%RH)

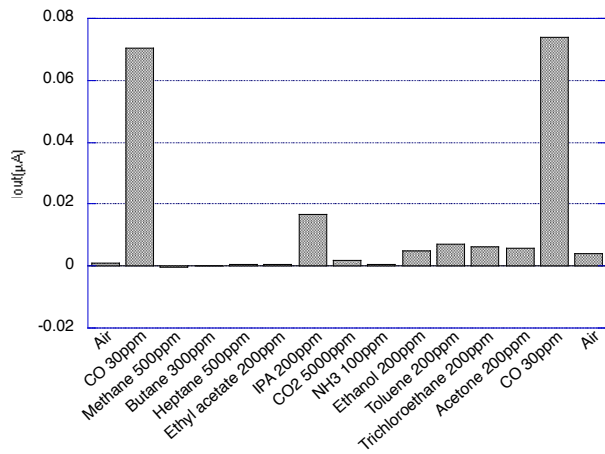

Figure 13a - Interference gas test (20°C/40%RH)

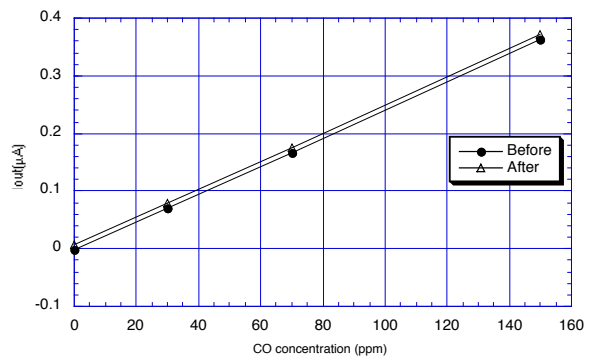

Figure 13b - Interference gas test (20°C/40%RH)

4-2 Long-term stability

Figure 14 shows long-term stability data for TGS5042. Test samples were stored in natural clean air under a short-circuit condition and measured at various intervals as dictated by the standard test conditions of UL2034, Sec. 38. The Y-axis shows the ratio of output current in 300ppm of CO at any point in time (I) over output current in 300ppm of CO on the first day of the test (I₀). This chart demonstrates very stable characteristics with negligible variation of less than ±5% for more than 900 days.

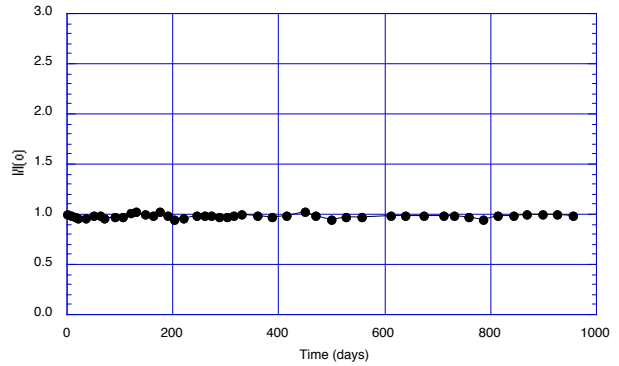

Figure 14 - Long term stability

4-3 Corrosion test

To demonstrate the durability of TGS5042 against corrosion, samples were subjected to test conditions called for by UL2034, Sec.58-Corrosion Test. Over a three-week period, a mixture of 100ppb of H₂S, 20ppb of Cl₂, and 200ppb of NO₂ was supplied to the sensors at a rate sufficient to achieve an air exchange rate of five times per hour. Figure 15 shows the CO sensitivity characteristics before and after exposure in the above conditions, demonstrating that TGS5042 is hardly influenced by such corrosive gases. In addition, the sensor's stainless steel housing did not show any sign of corrosion as a result of this test.

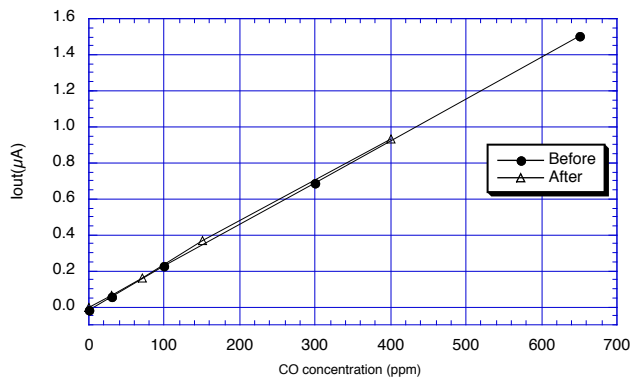

Figure 15 - Durability against corrosion

4-4 Variable ambient temperature test

To demonstrate the ability of TGS5042 to withstand the effects of high and low temperature, the "Variable Ambient Temperature Test" of UL2034, Sec. 45 was conducted.

(1) Operation in high and low temperature test

Figure 16a shows the results for the "Operation in High and Low Temperature Test" of UL2034, Sec. 45.1. The sensor was exposed to environments of 0°C/15%RH and 49°C/40%RH for at least three hours each, with measurements taken before and during the exposure in accordance with the test conditions of UL2034, Sec. 38. By plotting the output current values from these test measurements atop the data taken prior to this test at a constant 50%RH (representing standard temperature dependency), it can be seen that the test data are still in line with data taken at a constant RH. The conclusion which can be drawn is that, regardless of exposure to extremes of temperature and humidity, the sensor's output is not affected by humidity. As a result, TGS5042 can meet the requirements of UL2034, Sec. 45.1 by utilizing a simple temperature compensation method.

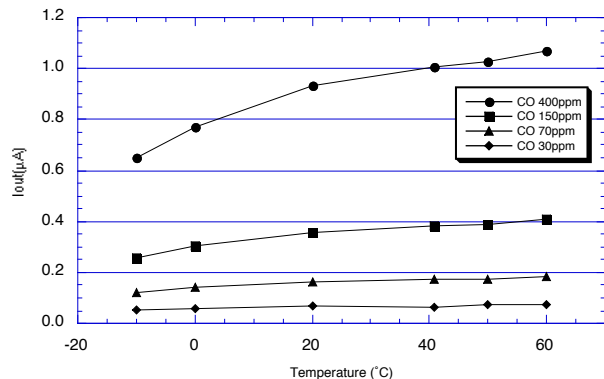

Figure 16a - Operation in high and low temperature (all data at 50%RH except Sec. 45.1 test points)

(2) Effect of shipping and storage

To verify the effects of shipping and storage, the sensor was tested under the conditions of UL2034, Sec. 45.2. Test samples in a short-circuited condition were subjected to 70°C for 24 hours, allowed to cool to room temperature for 1 hour, subjected to -40°C for 3 hours, and then allowed to warm up to room temperature for 3 hours. Figure 16b shows the CO sensitivity characteristics before and after the test, demonstrating that TGS5042 meets the requirement of UL2034, Sec. 45.2.

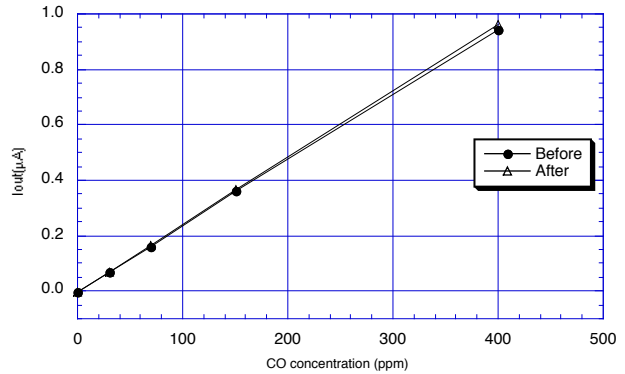

Figure 16b - Effects of shipping and storage

4-5 Humidity test

Figure 17a shows the results of testing the sensor under UL2034, Sec. 46A. The sensor was exposed in an atmosphere of 52±3°C/95±4%RH for a period of 168 hours, returned to normal air for 2 days, then followed by 168 hours exposure at 22±3°C/10±3%RH. The data demonstrates the stable characteristics in both low and high humidity conditions.

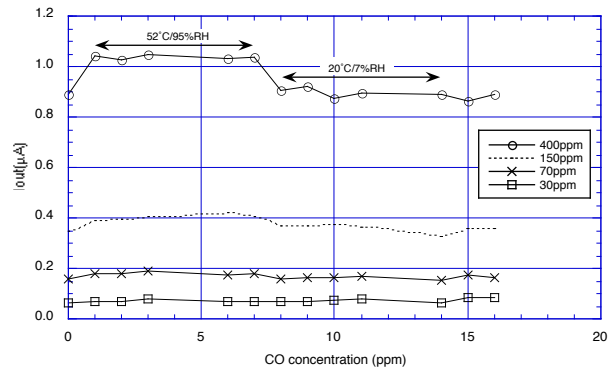

Figure 17a - Humidity test

Figure 17b shows data taken prior to the above test at a constant relative humidity of 50%. These curves represent the typical temperature dependency of the sensor. When plotting measurements taken at the environmental extremes specified on UL2034, Sec. 46A (52±3°C/95±4%RH and 22±3°C/10±3%RH) onto the temperature dependency curves, it can be seen that measurements taken at these extreme conditions still fall in line with the temperature dependency curve derived prior to testing. The conclusion which can be drawn is that, regardless of exposure to extremes of temperature and humidity, the sensor's output is not affected by humidity. As a result, TGS5042 can meet the requirements of UL2034, Sec. 46A by utilizing a simple temperature compensation method.

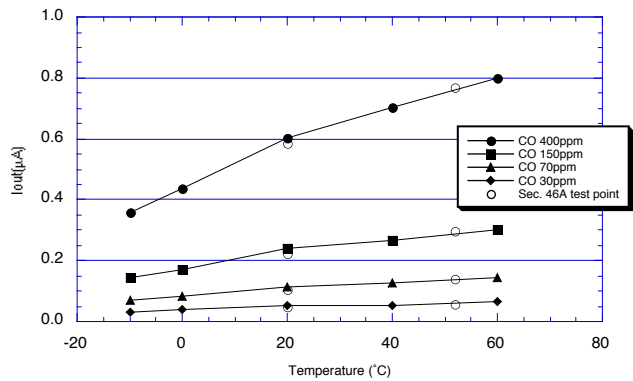

Figure 17b - Humidity test
(all data at 50%RH except Sec. 46A test points)

4-6 Stability test

(1) False alarm test

To show the sensor's behavior under continuous low level exposure to CO, samples were tested against the procedure detailed in UL2034, Sec. 41.1(c)-Stability Test. Test samples were exposed to 30ppm of CO continuously for a period of 30 days under standard circuit conditions. Figure 18 shows the CO sensitivity characteristics before and after the exposure test, demonstrating that detectors using TGS5042 will not give a false alarm as a result of continuous low level CO exposure.

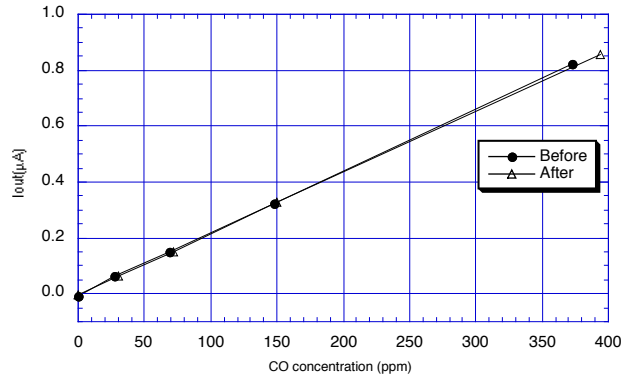

Figure 18 - False alarm test

(2) Temperature cycle test

In accordance with UL2034, Sec. 41.1(e)-Stability Test, test samples were exposed to ten cycles (<1 hour and >15 minutes) of temperature from 0°C/100%RH to 49°C/40%RH. Figure 19 shows CO sensitivity characteristics before and after the cycle test, demonstrating that TGS5042 is hardly influenced by the extreme conditions of the temperature cycle test.

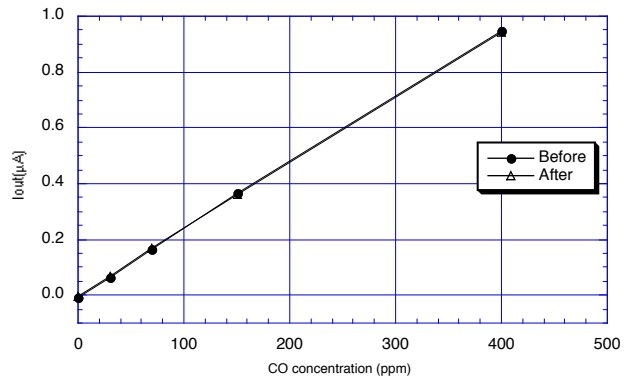

Figure 19 - Temperature cycle test

4-7 Sequential test

In UL2034, Sec. 41.3, a single lot of sample detectors are to be subjected to the following sequence of tests: Section 38, Section 41.1, Section 39, Section 45, and Section 46A. While TGS5042 meets the requirements of each of these test individually (*as shown elsewhere in this brochure*), this test is designed to demonstrate the sensor's ability to withstand all of these test when conducted in sequence. Figure 20 shows the results of sequentially testing the same lot of sensors. The good stability of the sensor's output signal indicates that TGS5042 can satisfy the requirements of UL2034, Sec. 41.3-Sequential Test.

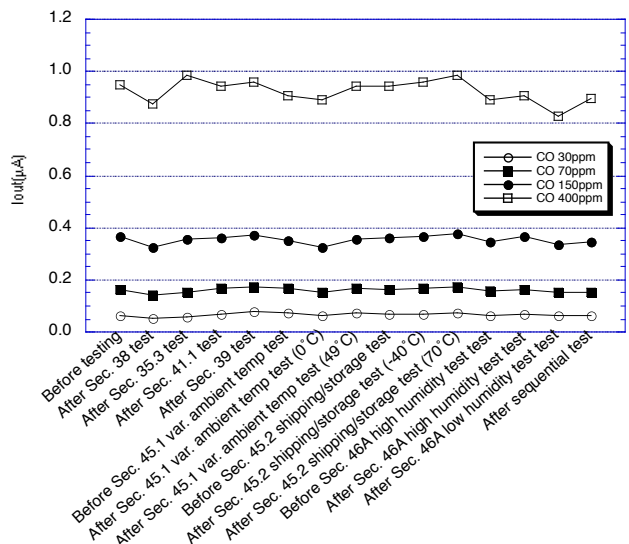

Figure 20 - Sequential test

4-8 Dust test

To judge the effect of dust contamination on TGS5042, approximately 2 ounces (0.06 kg) of cement dust, capable of passing through a 200 mesh screen, was circulated for 1 hour by means of a blower, enveloping the sensor in the test chamber. Air flow was maintained at an air velocity of approximately 50 fpm (0.25 m/s) at 20°C/40%RH.

Figure 21 shows the sensor's CO sensitivity characteristics before and after the dust exposure test. This data demonstrates that the dust test of UL2034, Sec. 53 has a negligible effect on CO sensitivity.

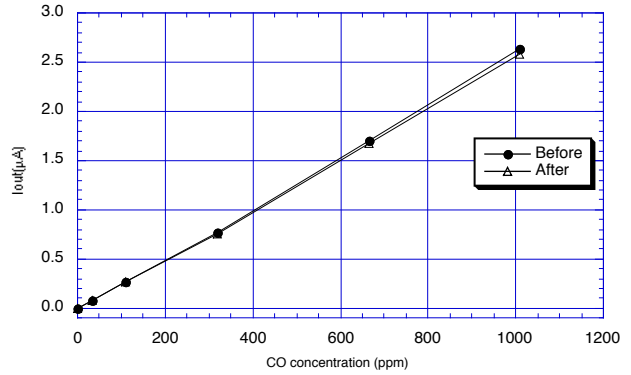

Figure 21 - Dust test

4-9 Water loss test

For evaluating the life expectancy of TGS5042 from the viewpoint of its water reservoir (which prevents the electrolyte from drying up), the weight loss of TGS5042 was periodically measured when stored at 20°C/50%RH, 50°C/10%RH and 70°C/5%RH respectively. Figure 22 demonstrates that the sensor's weight decreased linearly with time due to evaporation of the water. The rate of water loss under various temperature was related with the water vapor pressure at each temperature. According to calculations based on this rate of water loss and the differences in water vapor pressure in 20°C, 50°C and 70°C, the water (>4g initially) will last more than 7 years under natural residential conditions such as 20°C/40%RH.

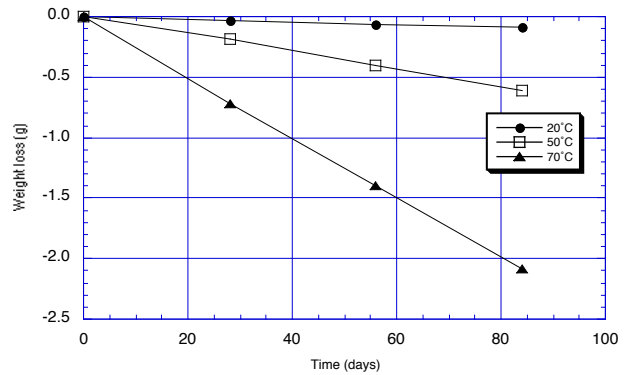

Figure 22 - Water loss test

5. Marking

The TGS5042 comes with a sticker attached to the sensor housing which contains important information. The two dimensional bar code contains information in the following 28-digit format:

Format: XXXXZZZZZZmmmmmmnnnnnnppppY

where: XXXX = current value (nA/ppm)

ZZZZZZmmmmmmnnnnnnpppp = serial number
(for internal tracking purpose in production and testing)

The one dimensional bar code indicates the sensor's sensitivity (slope) in numeric value as determined by measuring the sensor's output in 300ppm of CO:

xxxx = x.xxx nA/ppm

In user readable format, the sensor's Lot Number is printed below the two dimensional bar code (yymmdd), and the sensor's sensitivity per ppm (nA) is printed below the one dimensional bar code. Please note that three decimal places should be added to the sensitivity reading (e.g. 1027 should be read as 1.027 nA/ppm).

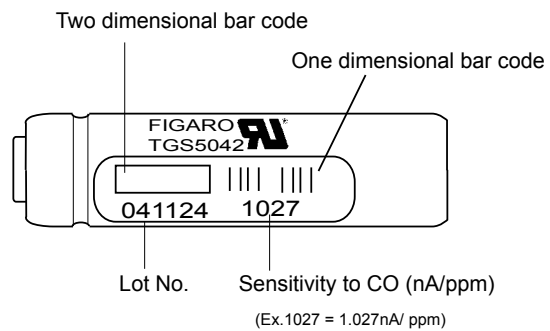

Figure 23 - TGS5042 markings

6. Notes

The following cautions regarding storage and installation of TGS5042 should be observed to prevent permanent damage to the sensor:

- 1) Install/store indoors, avoiding dew condensation, silicone vapor, and exposure to alkaline metals (Na, Li, etc.)
- 2) Avoid places where vibration or mechanical shock may occur.
- 3) Do not store in high humidity or temperature conditions.
- 4) Store and ship in a short-circuited form.
- 5) This sensor requires the existence of oxygen in the operating environment to function properly and to exhibit the characteristics described in this brochure. The sensor will not operate properly in a zero oxygen environment.

Figaro USA Inc. and the manufacturer, Figaro Engineering Inc. (together referred to as Figaro) reserve the right to make changes without notice to any products herein to improve reliability, functioning or design. Information contained in this document is believed to be reliable. However, Figaro does not assume any liability arising out of the application or use of any product or circuit described herein; neither does it convey any license under its patent rights, nor the rights of others.

Figaro's products are not authorized for use as critical components in life support applications wherein a failure or malfunction of the products may result in injury or threat to life.

FIGARO GROUP

HEAD OFFICE

Figaro Engineering Inc.

1-5-11 Senba-nishi
Mino, Osaka 562-8505 JAPAN
Tel.: (81) 72-728-2561
Fax: (81) 72-728-0467
www.figaro.co.jp
email: figaro@figaro.co.jp

OVERSEAS

Figaro USA Inc.

121 S. Wilke Rd. Suite 300
Arlington Heights, IL 60005 USA
Tel.: (1) 847-832-1701
Fax.: (1) 847-832-1705
www.figarosensor.com
email: figarousa@figarosensor.com

APPENDIX

TGS5042 Lead Configurations

Leads are connected to sensor electrodes when the sensors are shipped. There are two lead configurations available:

- A00 : Stainless steel (SUS) pin version
- B00 : Flexible nickel ribbon version

When ordering, please be sure to specify the lead configuration. Please refer to *Figure 24* on Page 15 for sensor dimensions on each model.

TGS5042-A00

Stainless steel (SUS) pin version

The solid SUS pins of the -A00 version enable the sensor to be more easily mounted and/or directly soldered onto a PCB.

Mechanical strength:

Withstand force - 6kg along a vertical axis (lead from metal can)

Vibration - frequency--10~500Hz (equiv. to 10G)
 duration--6 hours
 direction--x - y - z

Shock - acceleration of 100G, repeat 5 times

NOTE: When the sensor is shipped, the working electrode and counter electrode are connected (i.e. short circuited) by a spring in order to avoid polarization of the electrodes. To measure sensor output, the spring should be removed and the sensor connected to a measuring circuit.

TGS5042-B00

Flexible nickel ribbon version

For applications where there is insufficient space for mounting TGS5042-A00, such as in portable CO monitors, the TGS5042-B00 is a suitable alternative. This model can also be directly soldered onto a PCB.

Mechanical strength:

Withstand force - 1.5kg along a vertical axis (metal ribbon from metal can)

Vibration - frequency--10~500Hz (equiv. to 10G)
 duration--6 hours
 direction--x - y - z

Shock - acceleration of 100G, repeat 5 times

NOTE: The nickel ribbon leads are provided for the purpose of electrical connection and should not be used for affixing the sensor to a PCB. To secure the sensor and prevent disconnection of the leads, affix the sensor to a PCB using wire, two-sided tape, or other appropriate measures. When the sensor is shipped, the working electrode and counter electrode are connected (i.e. short circuited) by a metal ribbon in order to avoid polarization of the electrodes. To measure the sensor output, the ribbon should be cut and the sensor connected to a measuring circuit. The cutting point as indicated can be used to cut the ribbon easily.

APPENDIX (cont.)

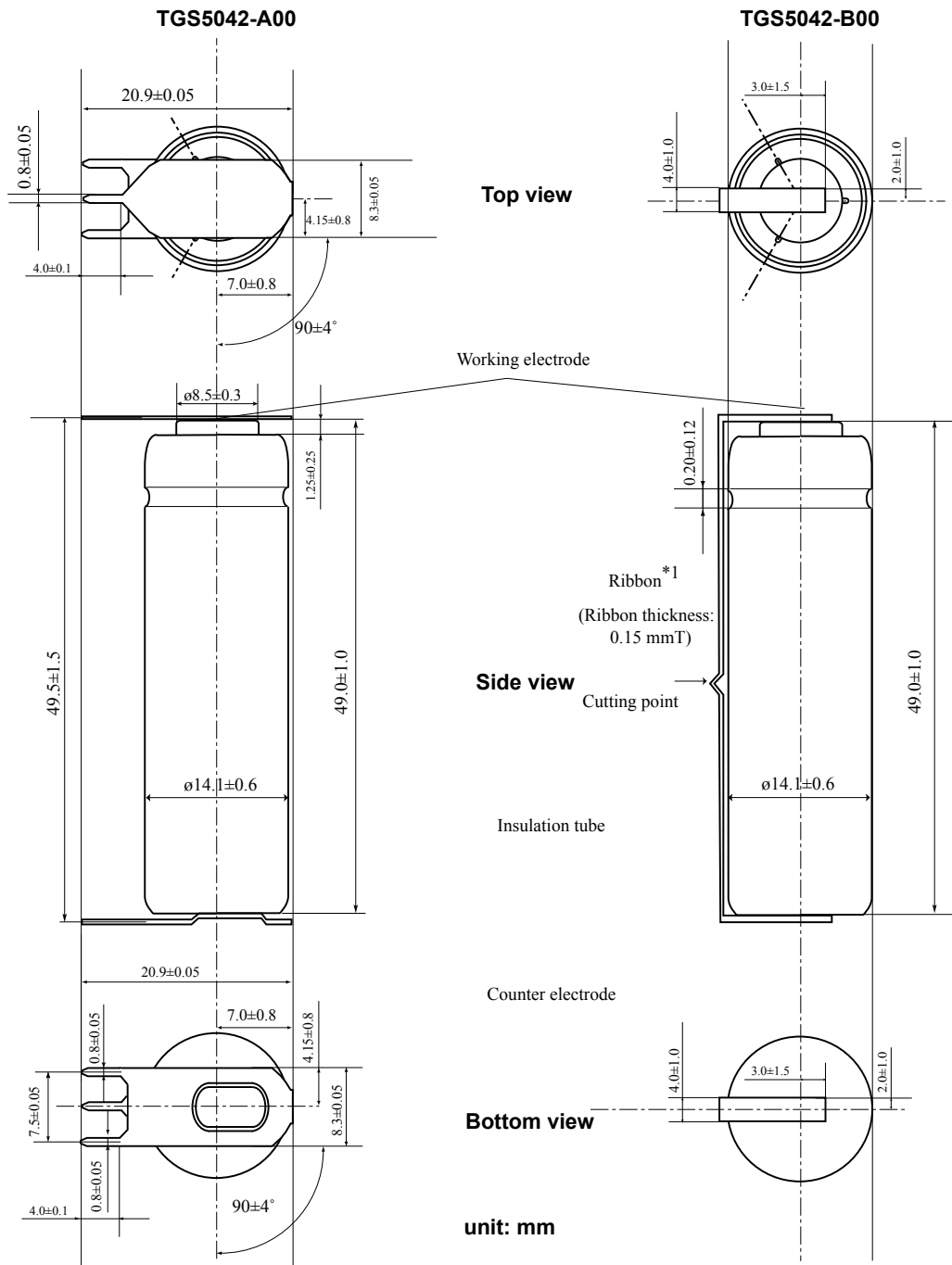

Figure 23 - TGS5042 Dimensions
(lead configurations)